



MB500

2-in-1
Travel System

GB Instruction Manual

ES Manual de instrucciones



IMPORTANT, RETAIN FOR FUTURE REFERENCE: READ CAREFULLY

Welcome to the familiee

Your trust in our product means the world to us, and we're thrilled to be a part of your parenting journey. Our team has worked tirelessly to ensure that the MB500 provides comfort, safety, and style for you and your little one. We're confident it will exceed your expectations. Should you have any questions or require assistance in the future, please don't hesitate to reach out. Thank you for choosing My Babiie; we wish you and your family countless wonderful strolls ahead.

Get to know your MB500 Travel System

Scan the QR code below on your camera app to be linked off to our page to get all the information you need for using your Travel System. From setting it up to how to fold it down, it's all there!



Warranty

We provide a 1 year warranty against manufacturing or material defects.

The warranty period is effective from the day of purchase and applicable to the UK and Ireland. If you made your purchase from an authorised retailer, please return your product to them.

If you bought your product via our website; mybabiie.com, please contact our Customer Service team via email (info@mybabiie.com). We are happy to refund any product if you change your mind about your purchase (if purchased from our website, mybabiie.com.) As long as you tell us within 30 days of receiving your goods. They must be returned in an unused condition, in the original, undamaged packaging and complete with all original parts and accessories. Proof of purchase is required.

What is not covered by the Guarantee?

- Failure to follow My Babiie user guide and maintenance instructions.
- Damage caused by non domestic use
- General wear and tear, for example: worn wheels, damaged rain covers, worn/torn fabric.
- Deliberate damage, misuse or neglect.
- Product which has been modified, undergone an unauthorised repair or used a non approved spare part.
- Car seats which have been involved in an accident, we recommend all car seats should be replaced if involved in an accident.
- Cosmetic damage.
- Parts subject to normal wear and tear, foam handles, rubber elements of wheels, signs of fabric wear.
- Loss incurred as a result of not being able to use a product whilst waiting for a spare part or repair.

A repair service is available for any item that sustains accidental damage at any point during its lifespan. If the damages are not covered by our guarantee, we will provide a quote for the repair costs on an individual basis. If you find yourself in need of spare parts that are not covered by the warranty, you can purchase each spare part on our website (subject to availability).

To read more about your guarantee, please visit mybabiie.com/guarantee.

Our guarantee is provided by My Babiie Ltd, Registered address: 15 Commercial Road, Paddock Wood, Kent, TN12 6EN .

Your statutory rights are not affected by the guarantee.

Registering your Warranty

To register your warranty please visit www.mybabiie.com/warranties

Registering for your product warranty allows you to claim repairs or replacements if your product develops a fault. It will also help us contact you in the event of a product issue that you may need to be made aware of.

Problems or Questions

If you have any questions about your product then please drop us an email at info@mybabiie.com and we will get back to to you as soon as possible. Alternatively, you can chat to us on our Live Support Chat on our website mybabiie.com or contact us via our social media channels.

Assembly instructions

- 1** Lift the release button to unlock the pushchair frame.

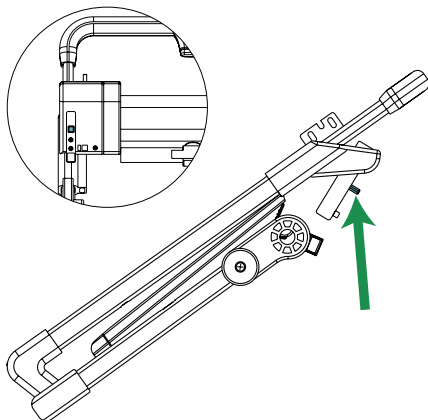

- 2** Lift the handle to open the pushchair frame.

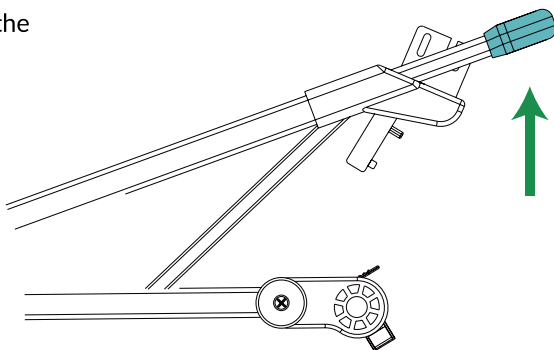

- 3** When the frame is opened you should hear a “click” sound on both sides of the frame. Please check that the pushchair frame is locked safely into position before use.

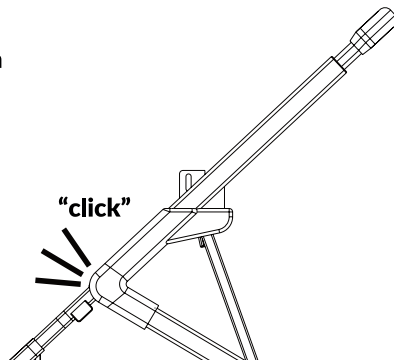

4 Assemble the rear wheels

Take one of the rear wheels and insert it into the plastic hole in the rear axle until it clicks into position. Repeat for the other side.

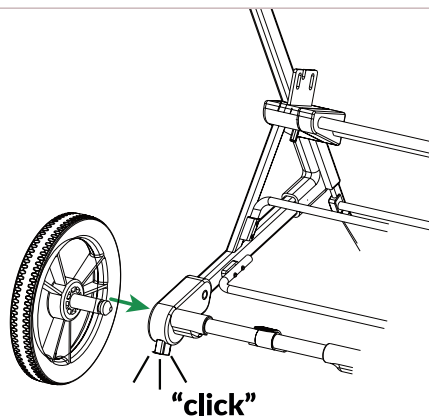

5 Remove the rear wheels

Pull the rear wheel release knob and remove the wheel by pulling it outwards.

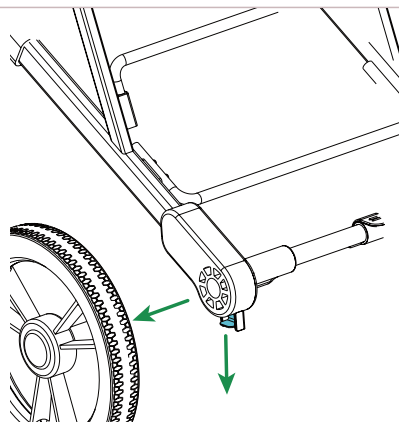

6 Apply the brake

Step down on the brake pedal. Lift the pedal to release the brake.

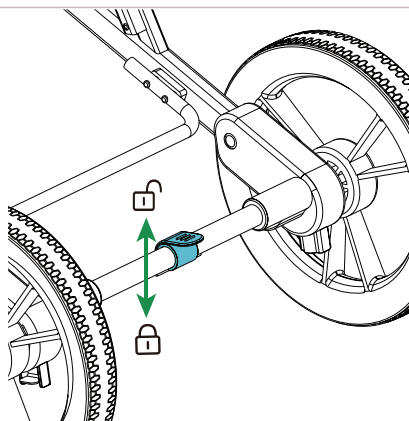

7 Assemble the front wheels

Take one of the front wheels and insert it into the plastic hole in the front frame until it clicks into position. Repeat for the other side.

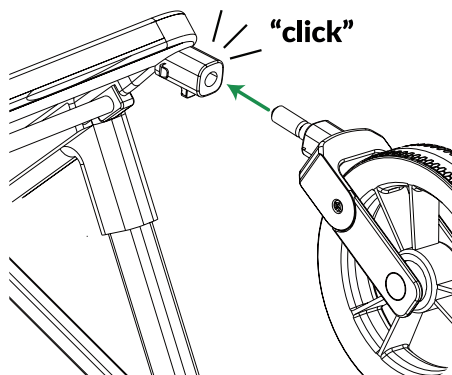

8 Remove the front wheels

Press the small metal pins as shown and at the same time pull out the wheel.

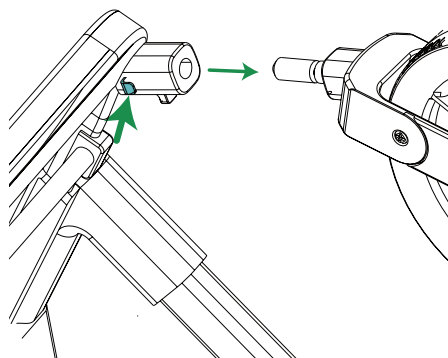

9 Locking the front wheels

Lift up the plastic button on the front wheels to lock into a fixed position. Press down the plastic button to release it, allowing 360° rotation.

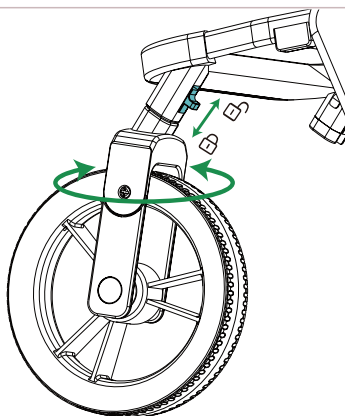

10 Assemble the seat

Pull up the lever on the top of the seat back to open the seat and to fold open the seat.

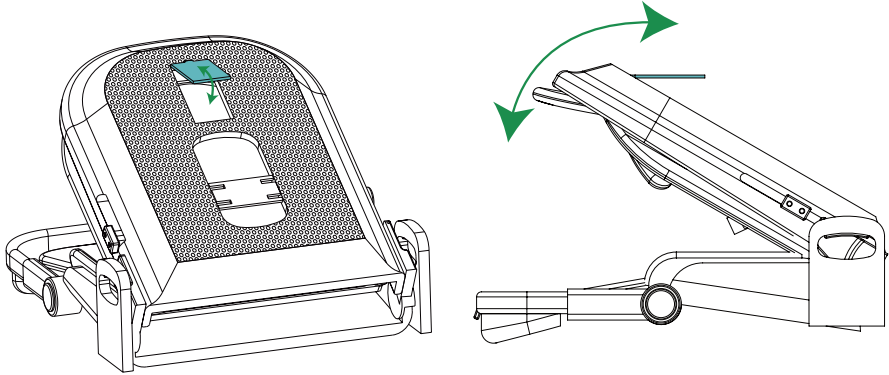

11 Canopy height adjustment

Press the button on the back side of the seat unit to adjust the height of the canopy and head rest. The height can be adjusted to 3 different positions.

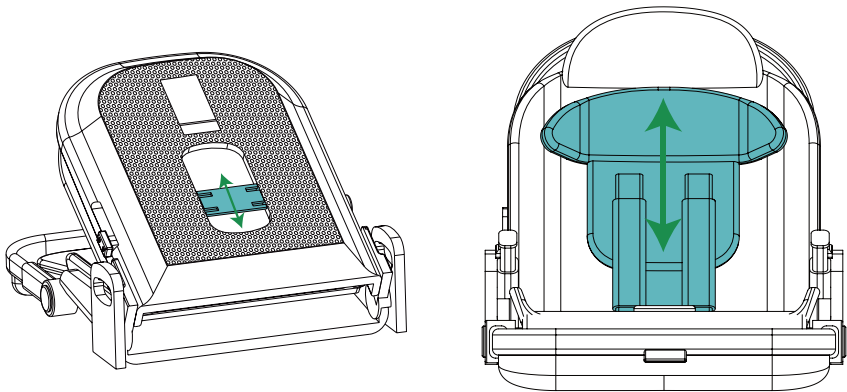

12 Assemble the canopy

Insert the hood plastic into the seat.

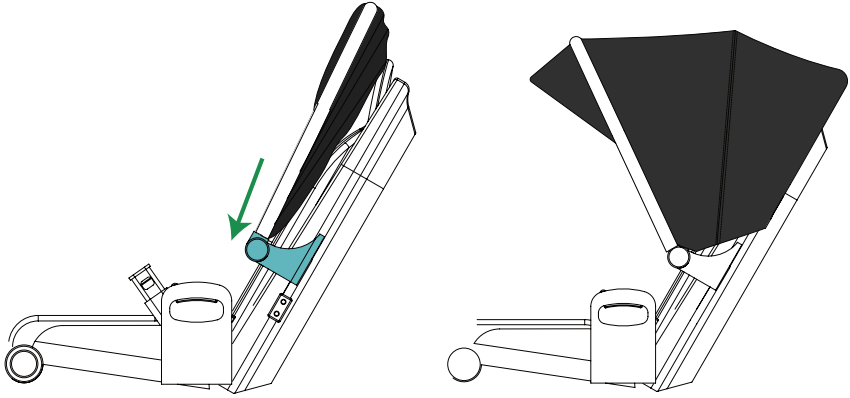

13 Assemble the bumper bar

Insert the bumper bar on both sides of the seat. Make sure to lock the bumper bar into place by hearing a “click” sound from both sides.

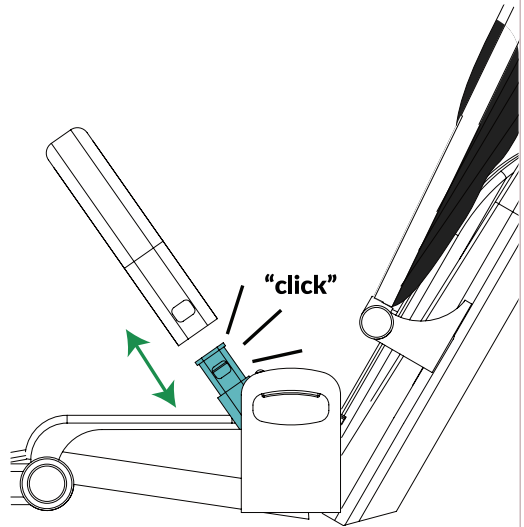

14 Assemble the seat

Click the seat onto the frame, making sure to hear a “click” sound from each side to let you know it is securely attached (a). To remove the seat press the button on each side and lift at the same time (b). The seat can be clicked back onto the frame facing the opposite direction (c)

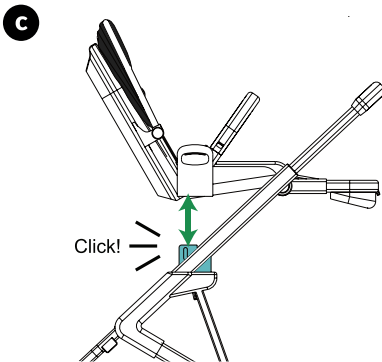
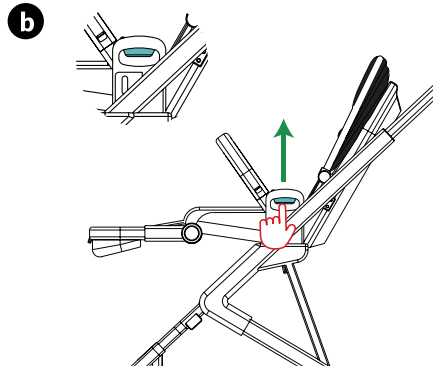
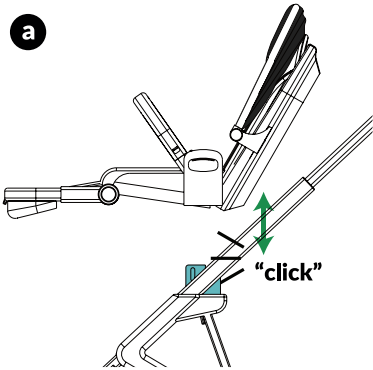

15 Seat recline

Pull the lever on the back of the seat to adjust the backrest position. There are 3 recline positions.

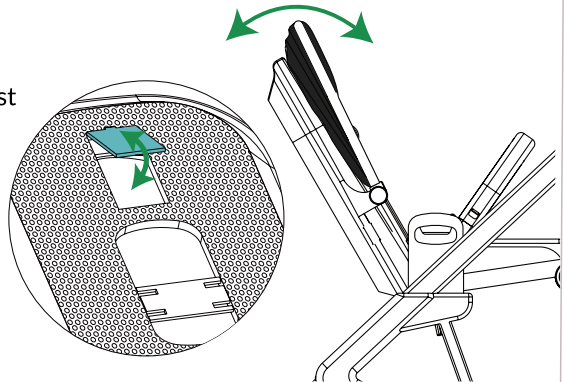

16 Adjust the canopy

The canopy can be pulled out to extend it and pushed back in to fold it back.

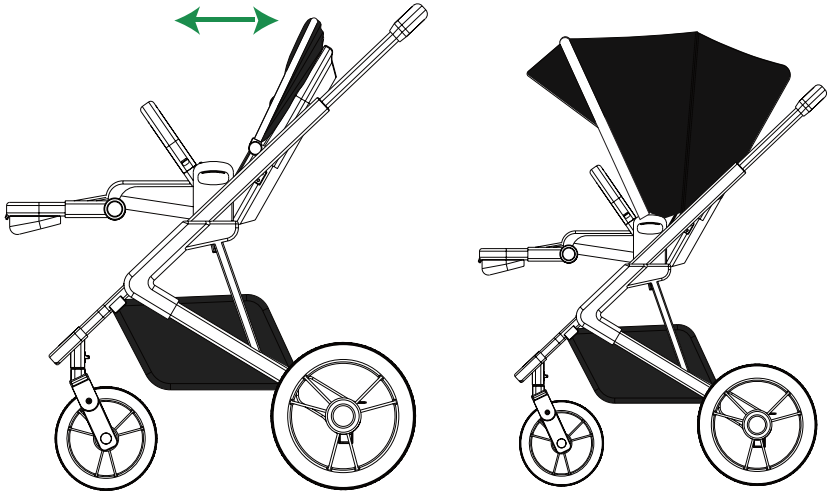

17 Bumper bar

Unlock and pull out one side of the bumper bar to rotate it 360°

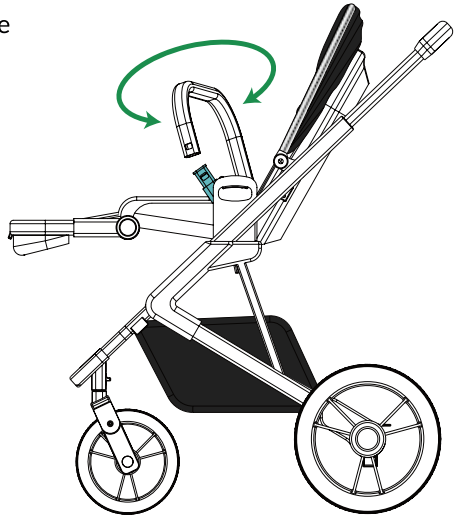

18 Adjust the handle height

Press the button on the handle to extend it.

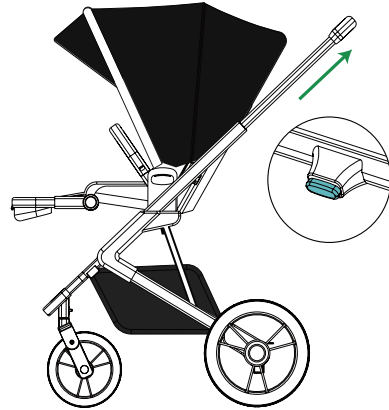

19 Adjust the foot rest

Press the buttons on the sides of the foot rest and move it into your desired position. There are 3 different foot rest positions.

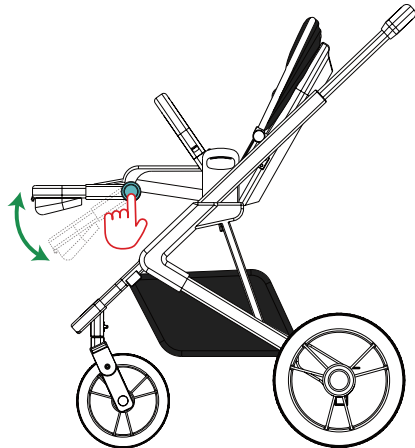

20 Extend the foot rest

The length of the foot rest is adjustable. Push the button under the footrest and pull to make it longer. To reduce the length, press the button and push the foot rest in.

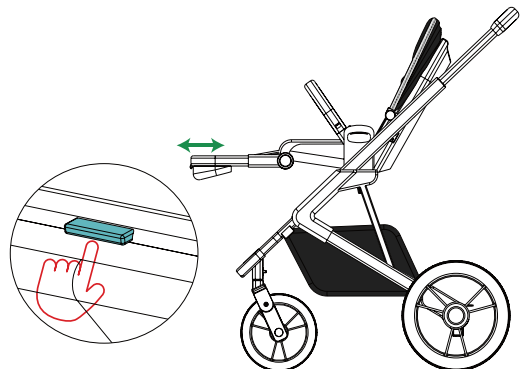

Folding the pushchair

1 Folding the pushchair with seat world facing

(a) Fold the seat forward using the recline lever on the back of the seat.

(b) Press the second lock and at the same time press the handle adjust button, then push down the handle with a little force to unlock the pushchair.

(c) - (d) Press the handle adjust button to lower the handle down, once the pushchair is folded completely you will hear a "click" sound. The pushchair can stand after folding.

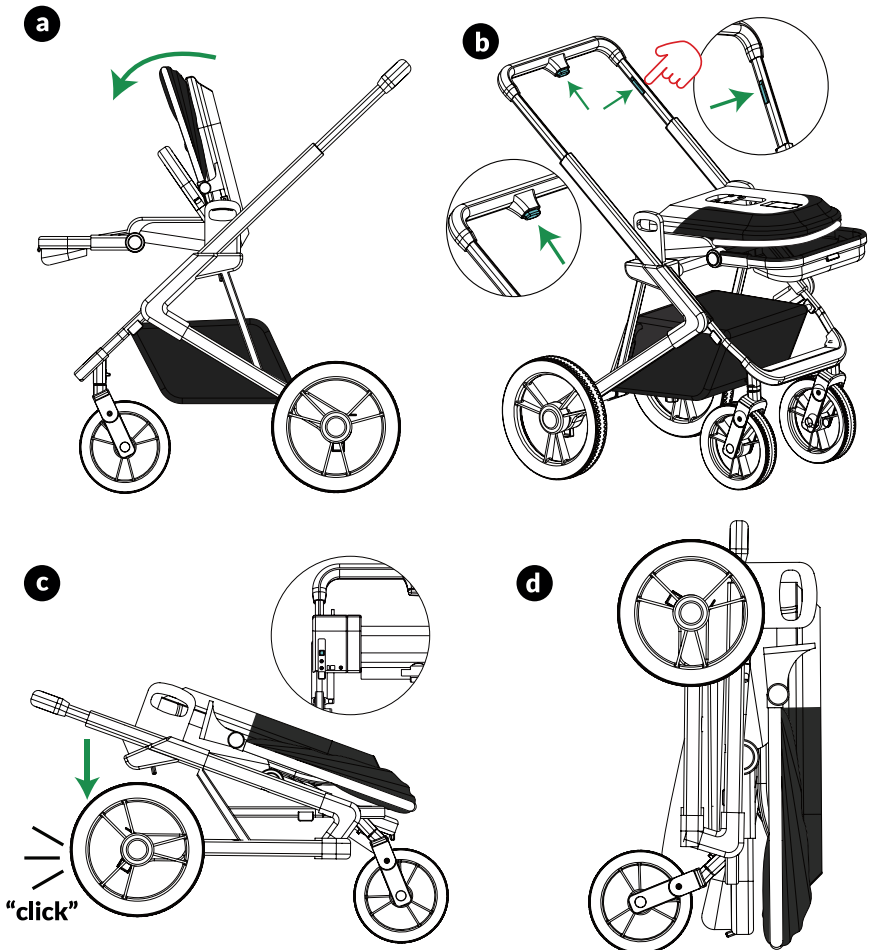

2 Folding the pushchair with seat parent facing

- (a) Fold the foot rest up towards the backrest.
- (b) Fold the back rest and foot rest to a horizontal position.
- (c) Press the second lock and at the same time press the handle adjust button, then push down the handle with a little force to unlock the pushchair.
- (d) Press the handle adjust button to lower the handle down, once the pushchair is folded completely you will hear a “click” sound. The pushchair can stand after folding.

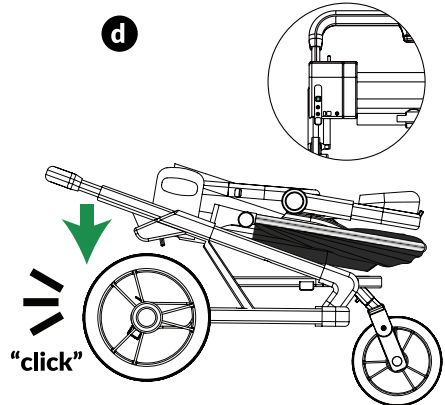
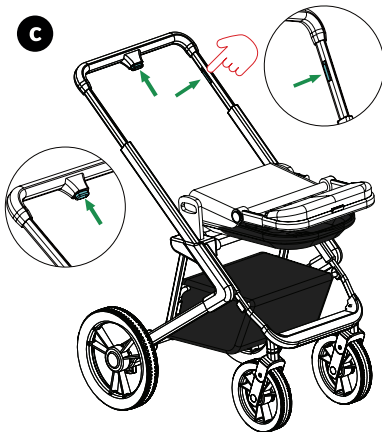
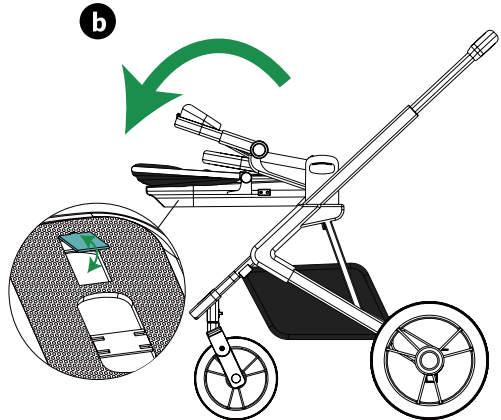
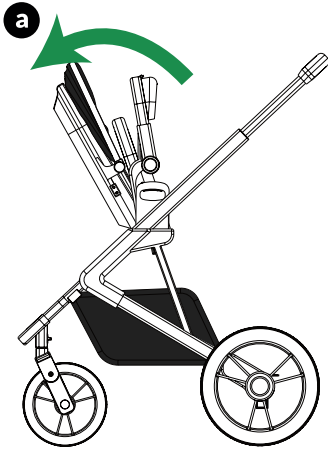

Safety harness

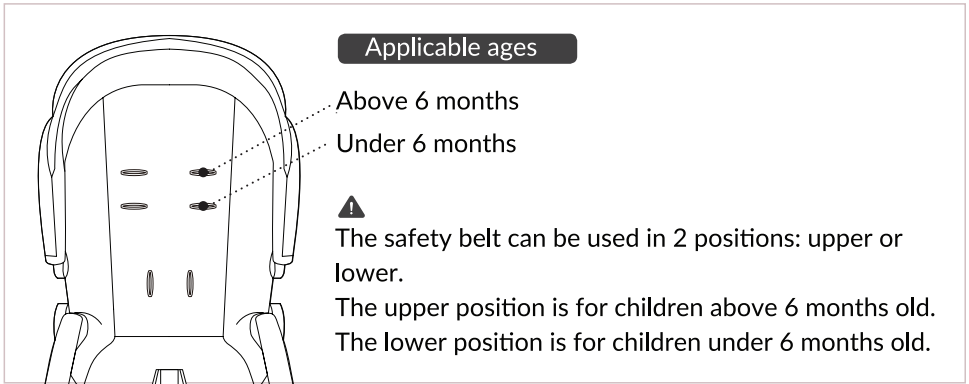

- 1** Insert part **b1** into part **a1**, insert part **b2** into part **a2**, a “click” will indicate that they are attached correctly.

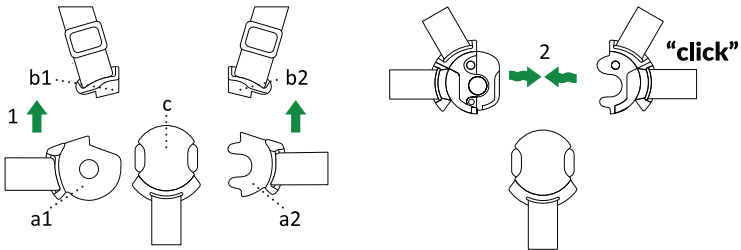

- 2** Place part **a2** on top of part **a1**, place the buckle component “**c**”, as shown in the image above on top of the combined parts **a1+a2**. A click will indicate they are attached correctly

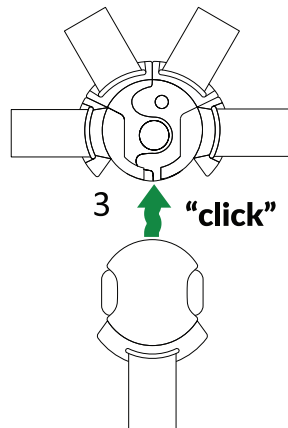

- 3** To release the buckle, press the buttons on either side.

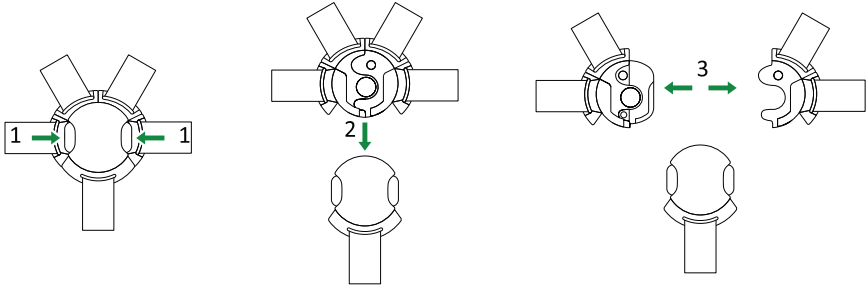

Assemble the carrycot

- 1** Remove the bedding and the mattress and then squeeze the metal tensioners on the bottom plate of the carrycot body in the direction shown until they lock into the special holders. You should hear a click sound once in place.

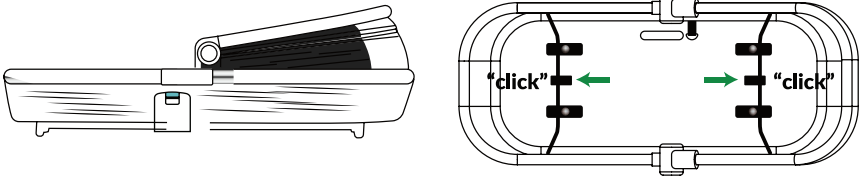

- 2** Reverse the above steps to collapse the carrycot down flat.

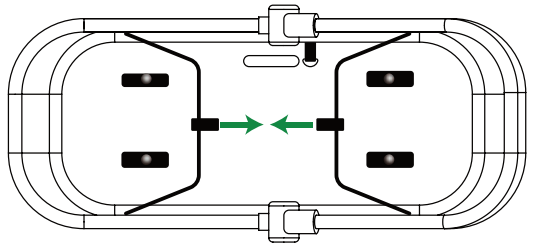

- 3** Press the buttons on either side of the carrycot canopy to adjust the canopy position. There are 4 different positions.

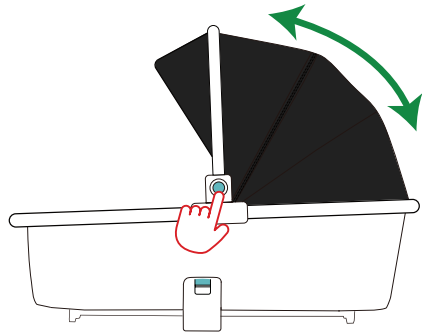

- 4** Place the carrycot onto the frame. You will hear a “click” sound to mean it is secured in place. Make sure you check the carrycot is properly secured onto the frame before use.

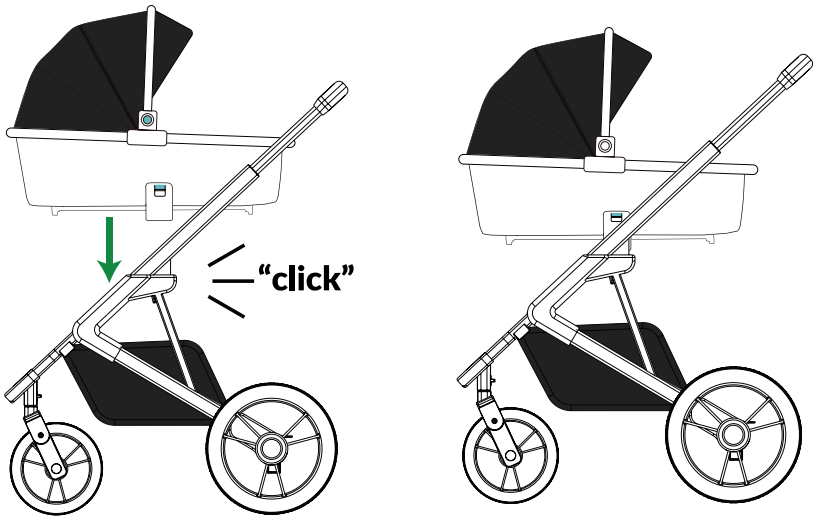

5 Removing carrycot from the frame

Press down the memory buttons on either side of the carrycot one by one. Then lift the carrycot up to remove from the frame.

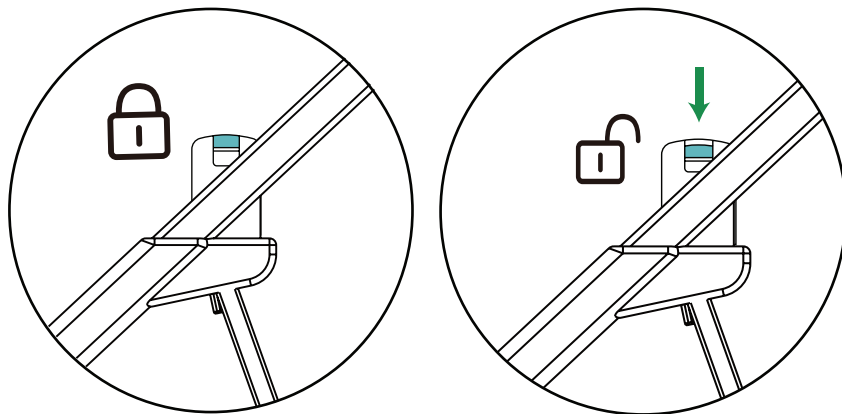

NOTE

The carrycot is designed for children up to 6 months old or up to 9kg, who cannot sit, kneel or pull themselves up by themselves.

Make sure the carrying handle is locked in the correct position before moving the pram body.

WARNING

Do not use additional mattresses of thickness of more than 15mm.

Attaching the Car Seat (sold separately)

- 1** Take the car seat adaptors and fix them onto the pushchair frame until you hear a click sound meaning they are correctly fitted.

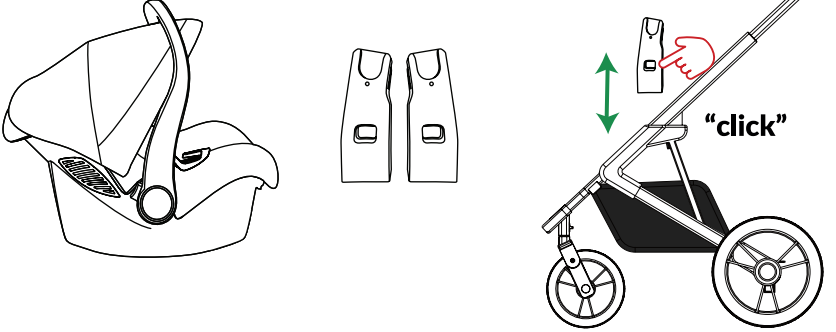

- 2** Align the car seat over the adaptors then push the car seat slightly down onto them until you hear a click sound meaning it is correctly fitted. Make sure you check the car seat is properly secured onto the frame before use.

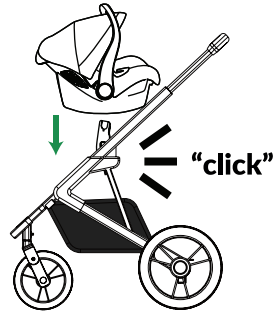

3

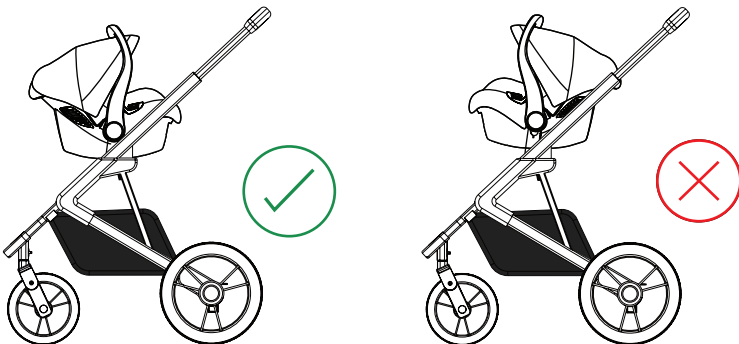

Pushchair warnings

IMPORTANT, RETAIN FOR FUTURE REFERENCE: READ CAREFULLY

Please read these instructions carefully before use and keep them for later reference.

Remove all packaging and non-permanent labels and dispose of safely before using this product. The safety of your child could be put at risk if you do not follow these instructions.

This stroller is designed for 1 child from 0 months up to a weight of 22 kg/36 months.

WARNING: Never leave your child unattended.

WARNING: Uneven or excessive loading of items on or in the stroller may cause the product to tip and may cause injury.

WARNING: Maximum intended weight within the shopping basket is 3kg.

WARNING: Ensure that all the locking devices are engaged before use.

WARNING: To avoid injury ensure that your child is kept away when unfolding and folding this stroller.

WARNING: Do not let your child play with this stroller.

WARNING: Always use the restraint system.

WARNING: Check that the pram body or seat attachment devices are correctly engaged before use.

WARNING: Do not put hot drinks or liquids in the cup holder.

WARNING: This product is not suitable for running or skating.

WARNING: Do not insert any additional mattresses into the stroller.

WARNING: Accessories which are not approved by the manufacturer shall not be used.

WARNING: This pushchair has been designed for one child and shall be used for the transport for only one child!

WARNING: Always use the crotch strap in combination with the waist belt.

WARNING: This stroller does not replace a cot or a bed. Should your child need to sleep, then it should be placed in a suitable cot or bed.

WARNING: Only replacement parts supplied or recommended by My Babiie shall be used.

WARNING: Any load attached to the handle and on the back of the backrest and on the sides of the stroller will affect the stability of the stroller.

WARNING: The parking device shall be engaged when placing and removing the children.

WARNING: The carrycot should not be used as soon as the child is able to sit by themselves, roll over or can push itself up on its hands and knees. Maximum weight of the child: 9kg

EN 1888-1:2018+A1:2022 and EN 1888-2:2018+A1:2022 approved

Carrycot warnings

- The product is only suitable for one (1) child.
- The product shall not be used as soon as the child is able to sit by himself, roll over and can push itself up on its hands and knees.
- Maximum weight of the child: 9kg.
- Do not add additional mattress.
- This product is compatible with the chassis of the stroller.
- Only use on a firm, horizontal level and dry surface.
- Do not let other children play unattended near the carry cot.
- Do not use if any part of the carry cot is broken, torn or missing.
- Do not leave flexible carrying handles inside the carry cot
- Never leave your child unattended.
- Only use original replacement parts. It may be unsafe to use substitutes.
- Be aware of the risks presented by an open fire and other heat sources such as electrical heaters, gas flames etc. especially if they are in the immediate vicinity of the carry cot.
- Only use the mattress supplied with the carry cot. Please check on a regular basis the carrying handle and the base including all feet for wear and damage of any kind.
- Never use the carry cot on a stand.
- Ensure that your child's head is never at a lower level than it's body when placed inside the carry cot.
- All carrying handles shall be left out of the pram body during use.

EN 1466:2023

Care and maintenance

- Please check on a regular basis that the brakes, wheels, latches, connecting elements, belt systems and seams are properly functional.
- Do not expose the stroller to strong sunshine.
- Sponge clean only.
- After use in rain or snow, the wheels should be lubricated and the stroller dried to prevent rust.
- Care for, clean and check this stroller regularly.
- Do not use accessories that have not been approved by the manufacturer.

Your child's safety is your responsibility

If you have a problem with this product or require replacement parts, please visit www.mybabiie.com/support

Register your product at: www.mybabiie.com/warranties

- 1** Levante el botón de liberación para desbloquear el marco del cochecito.

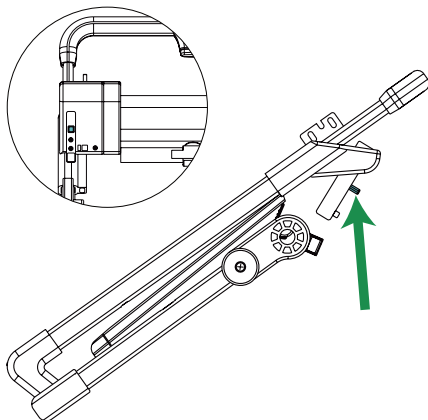

- 2** Levante el asa para abrir el marco del cochecito.

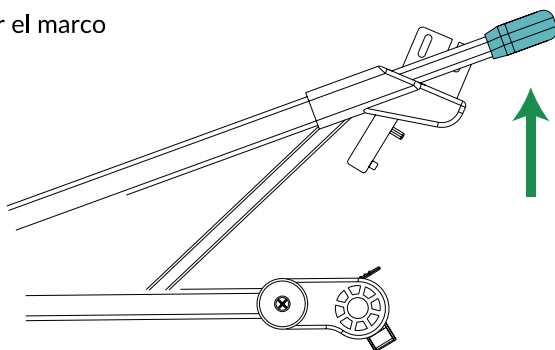

- 3** Cuando se abre el marco, debería escuchar un sonido de "clic" en ambos lados del marco. Compruebe que el armazón del cochecito esté bloqueado de forma segura en su posición antes de usarlo.

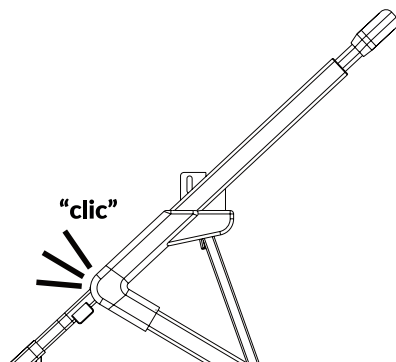

4 Montar las ruedas traseras.

Tome una de las ruedas traseras e insértela en el orificio de plástico del eje trasero hasta que encaje en su posición. Repite por el otro lado.

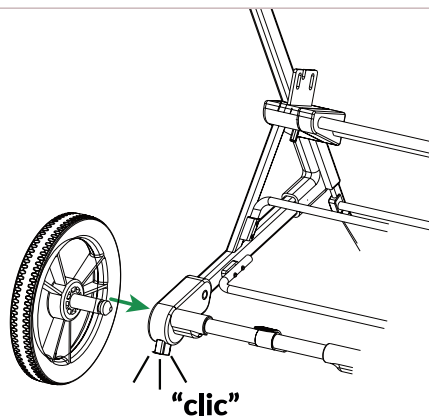

5 Retire las ruedas traseras

Tire de la perilla de liberación de la rueda trasera y retire la rueda tirando de ella hacia afuera.

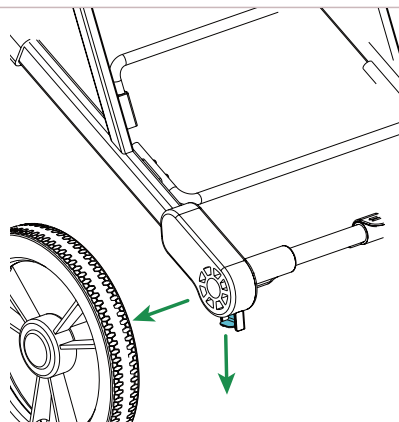

6 Poner el freno

Pise el pedal del freno. Levante el pedal para soltar el freno.

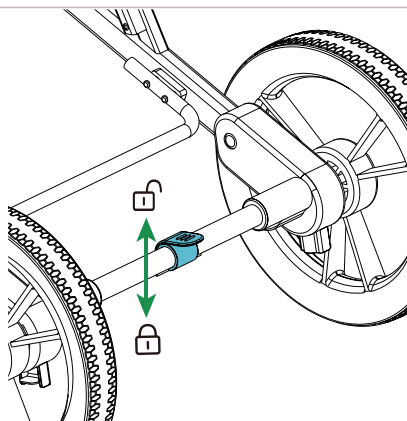

10 Montar el asiento

Levante la palanca en la parte superior del respaldo del asiento para abrir el asiento y plegarlo.

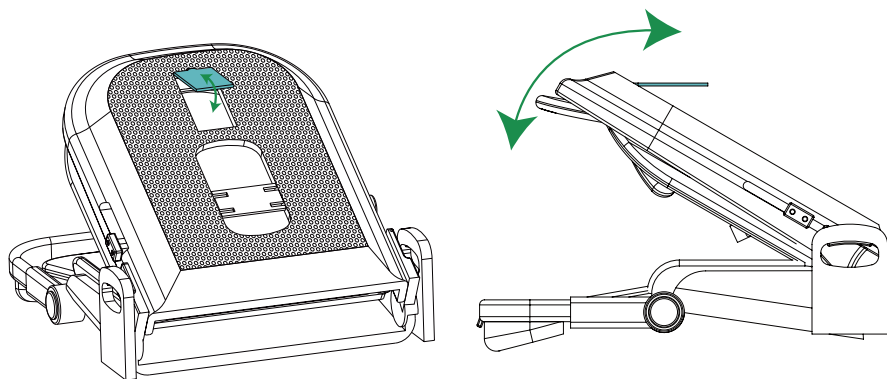

11 Ajuste de altura del dosel

Presione el botón en la parte trasera del asiento para ajustar la altura del dosel y el reposacabezas. La altura se puede ajustar en 3 posiciones diferentes.

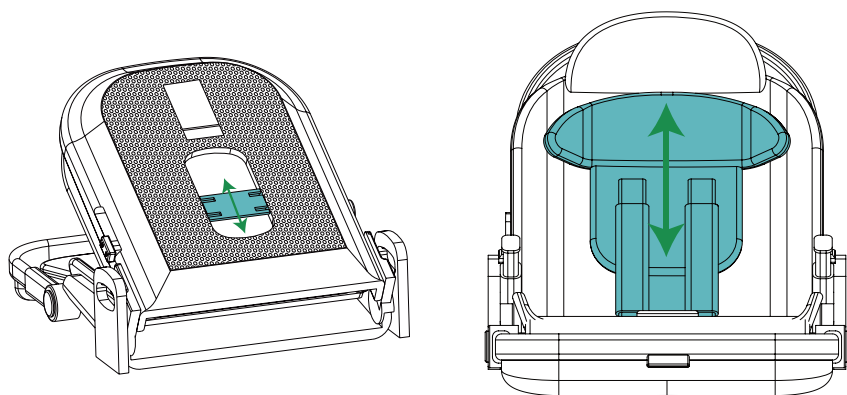

12 Montar el dosel

Inserte el plástico del capó en el asiento.

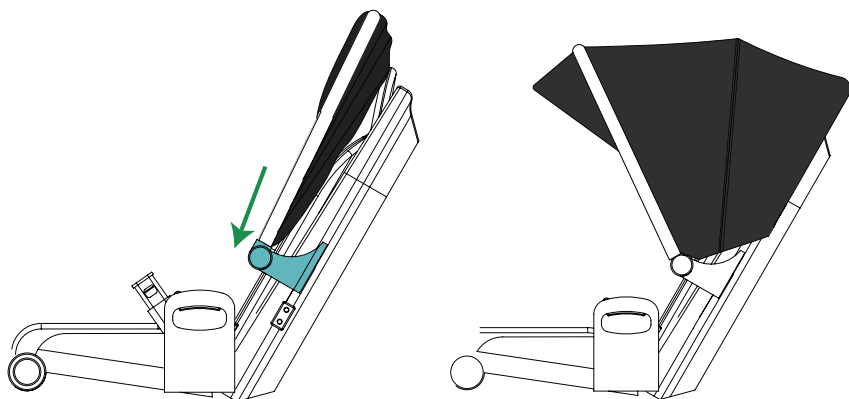

13 Montar la barra de parachoques

Inserte la barra protectora a ambos lados del asiento.
Asegúrese de bloquear la barra protectora en su lugar escuchando un sonido de "clik" en ambos lados.

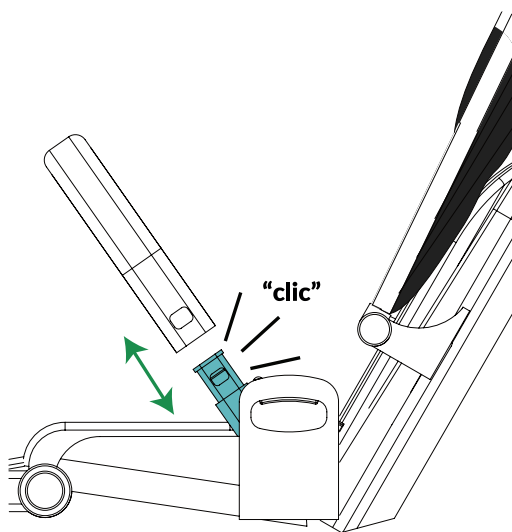

14 Montar el asiento

Haga clic en el asiento en el marco, asegurándose de escuchar un sonido de "clic" en cada lado para indicarle que está fijado de forma segura (a). Para quitar el asiento presione el botón a cada lado y levante al mismo tiempo (b). El asiento se puede volver a colocar en el marco mirando en la dirección opuesta (c)

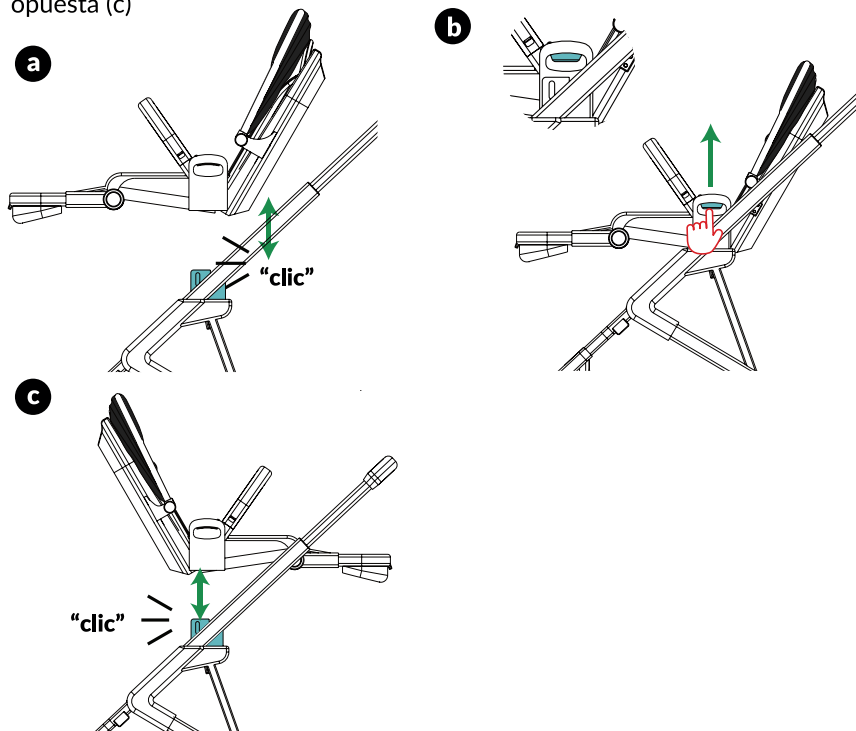

15 inclinación del asiento

Tire de la palanca en el respaldo del asiento para ajustar la posición del respaldo. Hay 3 posiciones de reclinado.

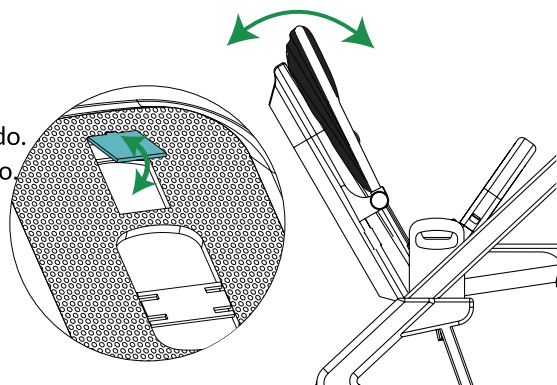

16 Ajustar el dosel

El dosel se puede sacar para extenderlo y empujarlo hacia adentro para plegarlo.

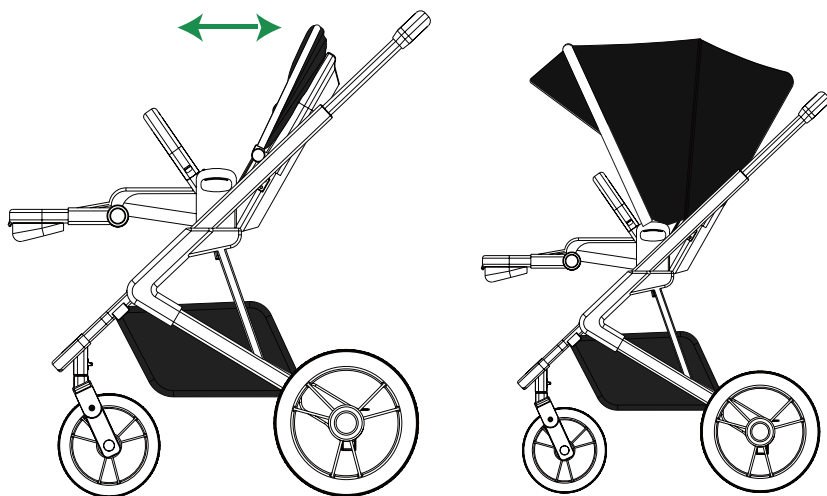

17 barra de parachoques

Desbloquee y extraiga un lado de la barra del parachoques para girarla 360°.

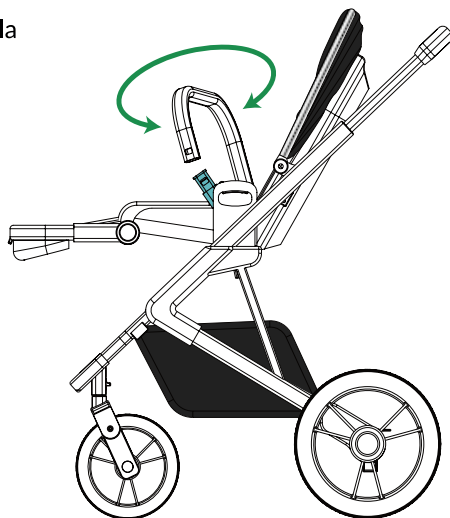

- 18 Ajustar la altura del mango**
Presione el botón en el mango para extenderlo.

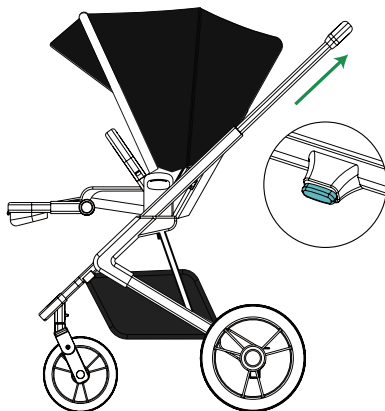

- 19 Ajustar el reposapiés**
Presione los botones a los lados del reposapiés y muévalo a la posición deseada. Hay 3 posiciones diferentes para el reposapiés.

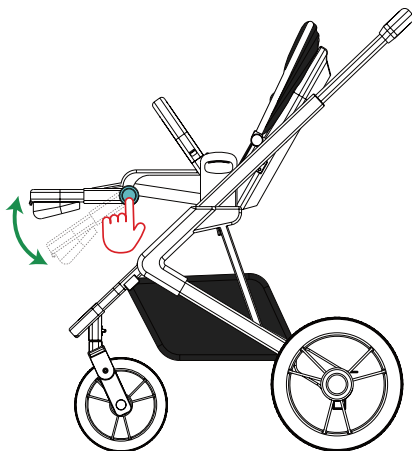

- 20 Extender el reposapiés**
La longitud del reposapiés es ajustable. Presione el botón debajo del reposapiés y tire para alargarlo. Para reducir la longitud, presione el botón y empuje el reposapiés hacia adentro.

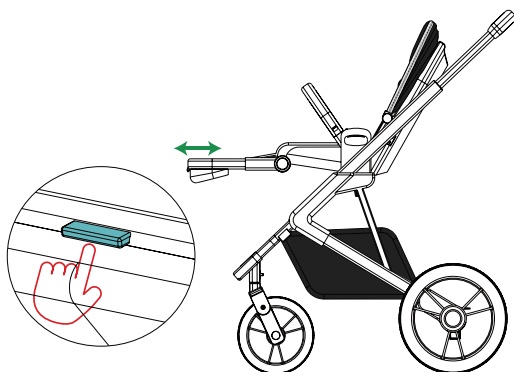

Plegar el cochecito

1 Plegar el cochecito con el asiento mirando al mundo

(a) Pliegue el asiento hacia adelante usando la palanca de inclinación en la parte posterior del asiento.

(b) Presione el segundo bloqueo y al mismo tiempo presione el botón de ajuste del mango, luego empuje el mango hacia abajo con un poco de fuerza para desbloquear el cochecito.

(c) - (d) Presione el botón de ajuste del mango para bajar el mango; una vez que el cochecito esté completamente plegado, escuchará un sonido de "clic". El cochecito puede mantenerse en pie después de plegarlo.

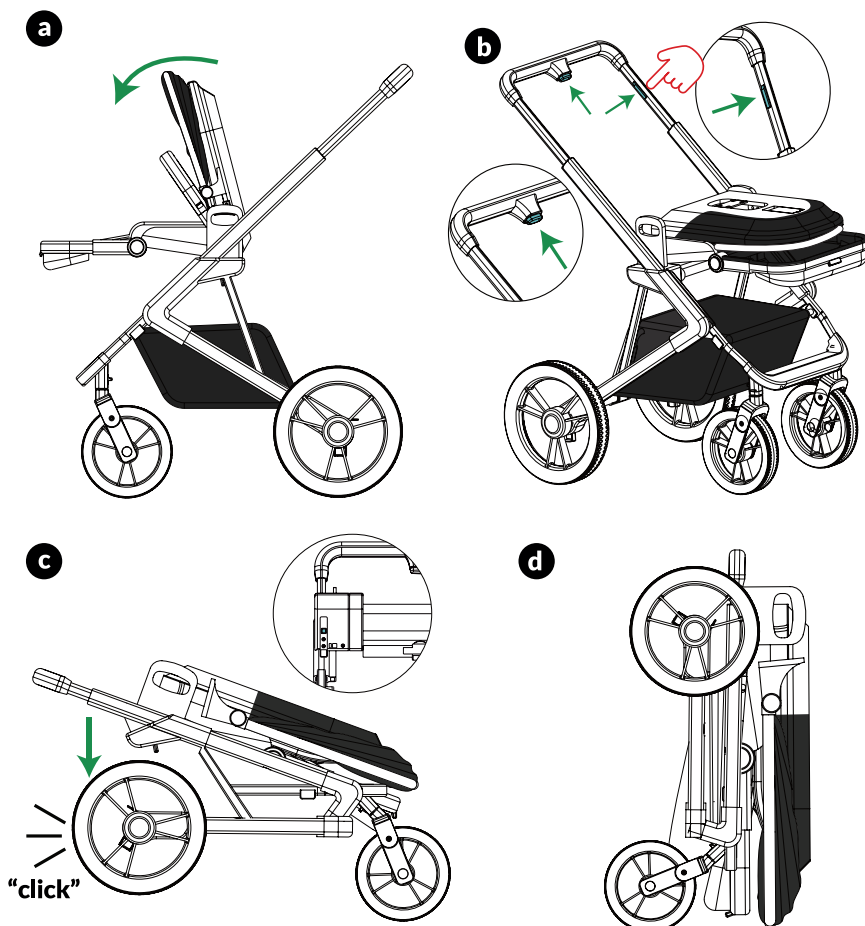

2 Plegar el cochecito con el asiento orientado hacia los padres

(a) Pliegue el reposapiés hacia el respaldo.

(b) Pliegue el respaldo y el reposapiés a una posición horizontal.

(c) Presione el segundo bloqueo y al mismo tiempo presione el botón de ajuste del mango, luego empuje el mango hacia abajo con un poco de fuerza para desbloquear el cochecito.

(d) Presione el botón de ajuste del mango para bajar el mango; una vez que el cochecito esté completamente plegado, escuchará un sonido de "clic". El cochecito puede mantenerse en pie después de plegarlo.

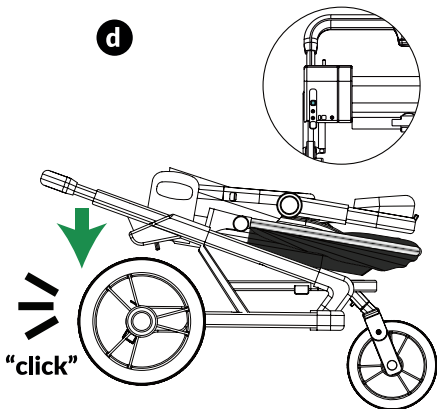
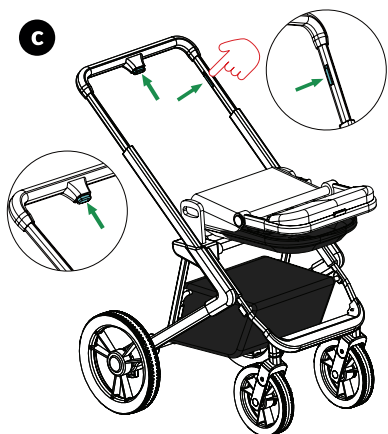
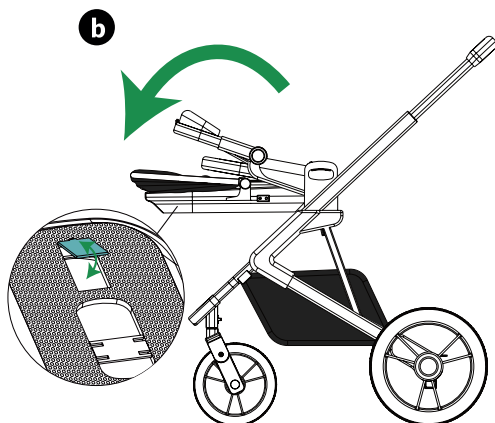
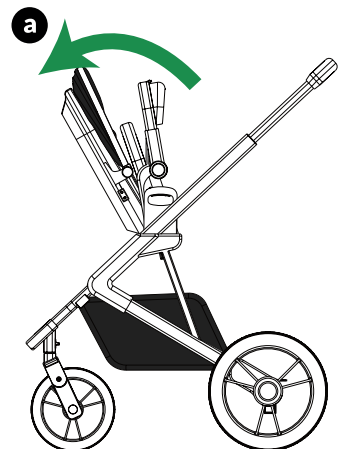

Arnés de seguridad

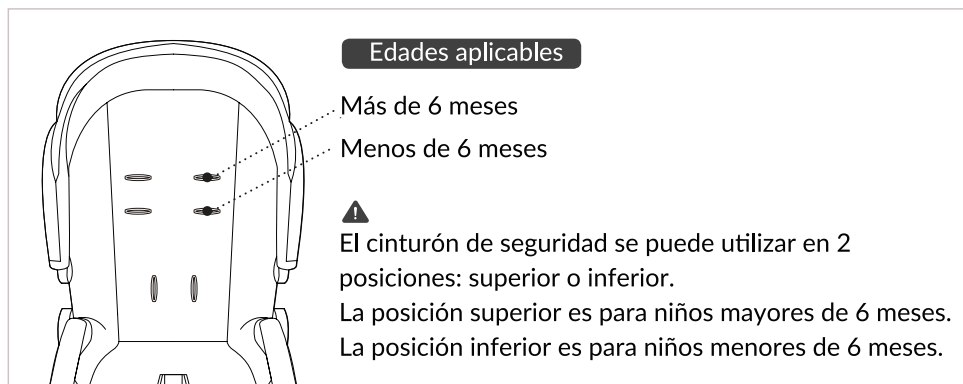

- 1** Inserte la parte b1 en la parte a1, inserte la parte b2 en la parte a2, un “clic” indicará que están acoplados correctamente.

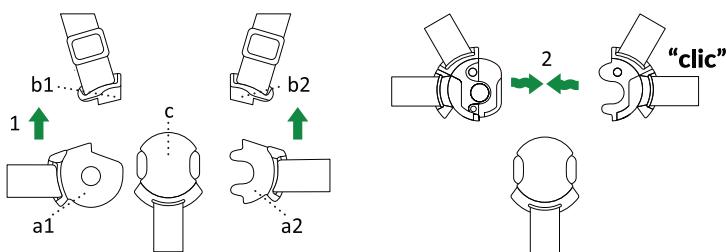

- 2** Coloque la parte a2 encima de la parte a1, coloque el componente de hebilla “c”, como se muestra en la imagen de arriba encima de las partes combinadas a1+a2. Un clic indicará que están conectados correctamente.

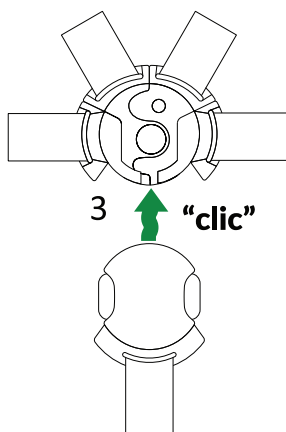

- 3** Para soltar la hebilla, presione los botones a cada lado.

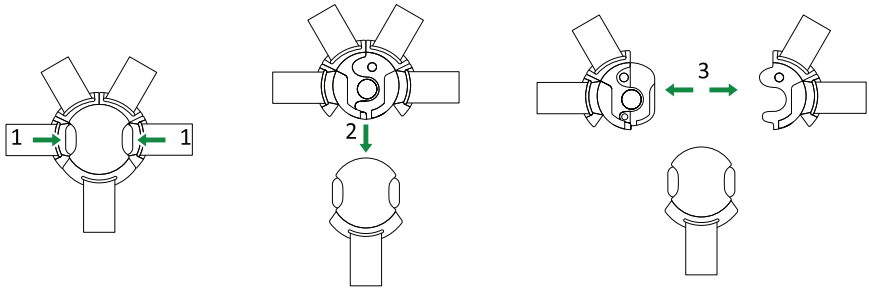

Montar el capazo

- 1** Retire la ropa de cama y el colchón y luego apriete los tensores metálicos de la placa inferior del cuerpo del capazo en la dirección que se muestra hasta que encajen en los soportes especiales. Debería escuchar un sonido de clic una vez que esté en su lugar.

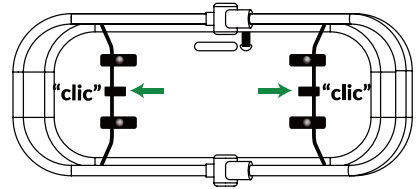
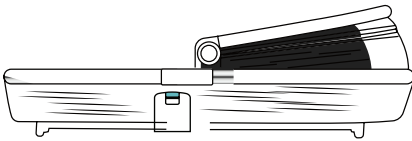

- 2** Invierta los pasos anteriores para plegar el capazo.

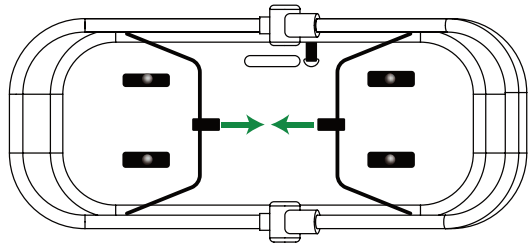

- 3** Presione los botones a cada lado de la capota del capazo para ajustar la posición de la capota. Hay 4 posiciones diferentes.

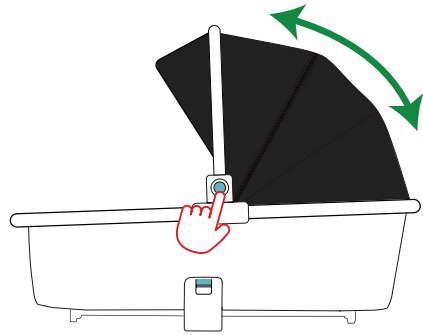

- 4** Coloque el capazo sobre el armazón. Escuchará un sonido de "clic" para indicar que está asegurado en su lugar. Asegúrese de comprobar que el capazo esté correctamente asegurado al armazón antes de usarlo.

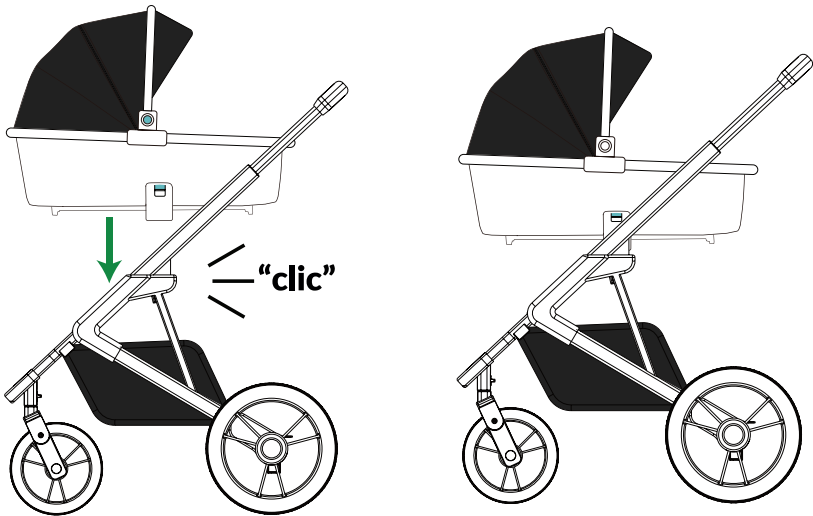

5 Quitar el capazo del armazón

Presione uno por uno los botones de memoria a cada lado del capazo. Luego levante el capazo para sacarlo del marco.

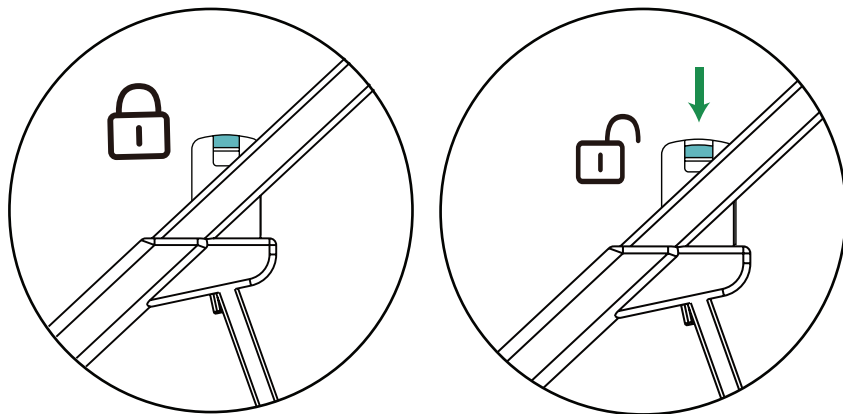

NOTA

El capazo está diseñado para niños de hasta 6 meses o hasta 9 kg, que no pueden sentarse, arrodillarse ni levantarse por sí solos.

Asegúrese de que el asa de transporte esté bloqueada en la posición correcta antes de mover el cuerpo del cochecito.

ADVERTENCIA

No utilice colchones adicionales con un grosor superior a 15 mm.

Colocación del asiento para el automóvil

(se vende por separado)

- 1** Tome los adaptadores de la silla de auto y fíjelos al marco del cochecito hasta que escuche un clic que indica que están correctamente instalados.

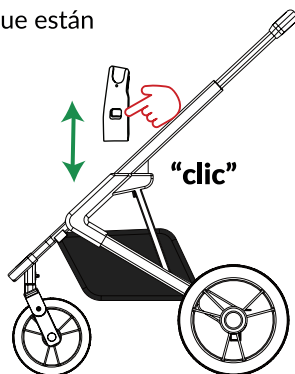
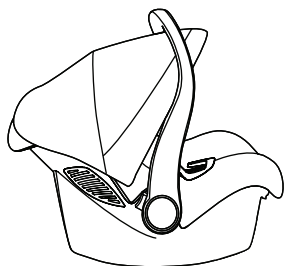

- 2** Alinee el asiento para el automóvil sobre los adaptadores y luego empujelo ligeramente hacia abajo sobre ellos hasta que escuche un clic, lo que significa que está correctamente instalado.

Asegúrese de comprobar que el asiento para el automóvil esté correctamente asegurado al marco antes de usarlo.

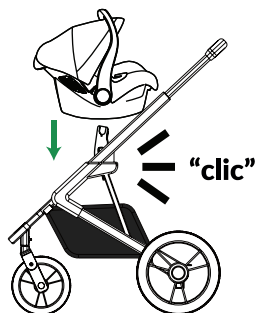

3

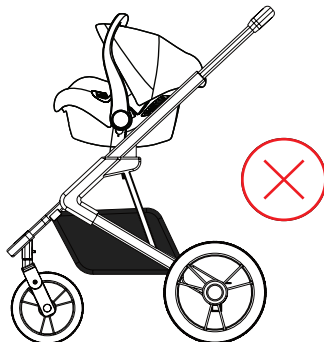
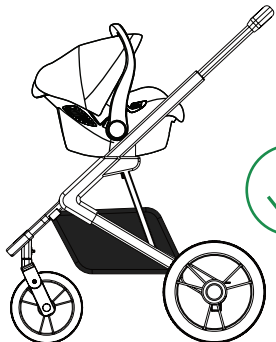

Advertencias sobre el cochecito

IMPORTANTE, CONSERVAR PARA FUTURA CONSULTA: LEA DETENIDAMENTE

Lea atentamente estas instrucciones antes de usarlas y consérvelas para consultarlas en el futuro.

Retire todos los embalajes y etiquetas no permanentes y deséchelos de forma segura antes de usar este producto. La seguridad de su hijo podría correr riesgo si no sigue estas instrucciones.

Este cochecito está diseñado para 1 niño desde 0 meses hasta un peso de 22 kg/36 meses.

ADVERTENCIA: Nunca deje a su hijo desatendido.

ADVERTENCIA: La carga desigual o excesiva de artículos sobre o dentro del cochecito puede hacer que el producto se incline y cause lesiones.

ADVERTENCIA: El peso máximo previsto dentro de la cesta de la compra es de 3 kg.

ADVERTENCIA: Asegúrese de que todos los dispositivos de bloqueo estén activados antes de su uso.

ADVERTENCIA: Para evitar lesiones, asegúrese de mantener alejado a su hijo cuando despliegue y pliegue este cochecito.

ADVERTENCIA: No deje que su niño juegue con este cochecito.

ADVERTENCIA: Utilice siempre el sistema de retención.

ADVERTENCIA: Compruebe que el cuerpo del cochecito o los dispositivos de fijación del asiento estén correctamente enganchados antes de su uso.

ADVERTENCIA: No coloque bebidas ni líquidos calientes en el portavasos.

ADVERTENCIA: Este producto no es apto para correr o patinar.

ADVERTENCIA: No inserte ningún colchón adicional en el cochecito.

ADVERTENCIA: No se deben utilizar accesorios que no estén aprobados por el fabricante.

ADVERTENCIA: ¡Este cochecito ha sido diseñado para un niño y se utilizará para el transporte de un solo niño!

ADVERTENCIA: Utilice siempre la correa de la entrepierna en combinación con el cinturón.

ADVERTENCIA: Este cochecito no sustituye a una cuna ni a una cama. Si su hijo necesita dormir, deberá colocarlo en una cuna o cama adecuada.

ADVERTENCIA: Sólo se utilizarán piezas de repuesto suministradas o recomendadas por My Babiie.

ADVERTENCIA: Cualquier carga sujeta al asa y en la parte posterior del respaldo y en los lados del cochecito afectará la estabilidad del cochecito.

ADVERTENCIA: El dispositivo de estacionamiento deberá estar activado al colocar y retirar a los niños.

ADVERTENCIA: El capazo no debe utilizarse tan pronto como el niño sea capaz de sentarse solo, darse la vuelta o levantarse sobre sus manos y rodillas. Peso máximo del niño: 9kg

Aprobado EN 1888-1:2018+A1:2022 y EN 1888-2:2018+A1:2022

Advertencias del capazo

- El producto sólo es apto para un (1) niño.
- El producto no se debe utilizar tan pronto como el niño sea capaz de sentarse solo, darse la vuelta y poder levantarse sobre sus manos y rodillas.
- Peso máximo del niño: 9kg.
- No agregue colchón adicional.
- Este producto es compatible con el chasis de la silla de paseo.
- Úselo únicamente sobre una superficie firme, nivelada horizontal y seca.
- No deje que otros niños jueguen solos cerca del capazo.
- No lo utilice si alguna pieza del capazo está rota, rasgada o falta.
- No deje asas de transporte flexibles dentro del capazo.
- Nunca deje a su hijo desatendido.
- Utilice únicamente piezas de repuesto originales. Puede que no sea seguro utilizar sustitutos.
- Sea consciente de los riesgos que presentan un fuego abierto y otras fuentes de calor como calentadores eléctricos, llamas de gas, etc., especialmente si se encuentran en las inmediaciones del capazo.
- Utilice únicamente el colchón suministrado con el capazo. Compruebe periódicamente el asa de transporte y la base, incluidas todas las patas, para detectar desgaste o daños de cualquier tipo.
- Nunca utilice el capazo sobre un soporte.
- Asegúrese de que la cabeza de su hijo nunca esté a un nivel más bajo que su cuerpo cuando se coloque dentro del cuna portátil.
- Todas las asas de transporte deberán dejarse fuera del cuerpo del cochecito durante su uso.

EN 1466:2023

Cuidado y mantenimiento

- Compruebe periódicamente que los frenos, ruedas, pestillos, elementos de conexión, correas Los sistemas y las costuras funcionan correctamente.
- No exponga el cochecito a la luz solar intensa.
- Limpiar únicamente con esponja.
- Después de usarlo bajo la lluvia o la nieve, se deben lubricar las ruedas y secar el cochecito para evitar óxido.
- Cuide, limpie y revise este cochecito con regularidad.
- No utilice accesorios que no hayan sido aprobados por el fabricante.

La seguridad de tu hijo es tu responsabilidad.

Si tiene algún problema con este producto o necesita piezas de repuesto, visite www.mybabiie.com/support

Registre su producto en: www.mybabiie.com/warranties

Pushchair Do's & Don'ts



Do use your brakes!

Ensure the parking brake is engaged during the loading and unloading of children & when the stroller is stationary.

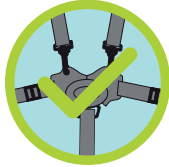

Do always use the restraint system!

Ensure that the child restraint system is correctly fitted at all times.



Do keep your stroller clean and dirt free.

Use a clean white cloth, warm water and a mild detergent to keep your stroller clean.



Do always keep two hands on the handles when pushing.

You could lose control of your stroller if not steering with both hands.



Do follow manufacturers instructions when assembling and using your stroller.

For safety, please refer to our instruction manuals or contact customer support if you're unsure.



Don't use your stroller up and down stairs!

Don't use your stroller up or down stairs or to bump kerbs.



Don't hang bags off the handles!

Bags and other items should not be hung from the handles as this can affect the stability of the stroller.



Don't run or skate with your stroller!

Our products are not suitable for running or skating.



Don't carry the stroller with baby inside!

Our strollers are not designed to be carried with your baby inside them.



Don't put hot drinks in the cup holder.

Hot drinks burn and can easily spill from the bottle holder.



Don't jetwash your stroller.

Some jet washers are very powerful and could damage parts of your stroller!



Don't leave your child un-attended in their stroller.

Always keep your child and stroller in view to avoid accidents.



Don't treat your stroller like a trolley.

Don't load your stroller up with all your shopping as they are not built for this purpose and could cause damage.



Don't use your stroller as a bumper cart!

Damage can easily occur if your stroller is knocked into other things.



Don't smoke around your stroller

We wouldn't want your stroller or little one getting hurt or damaged!



Don't leave your stroller unattended on extreme gradients.

Even with your brakes on your stroller is at risk from tipping or sliding on extreme gradients!



Don't sit in the strollers unless the user is under the guideline weight.

Our strollers are designed to hold a maximum weight. If exceeded this will cause damage!



Do enjoy your product!

Go out and have fun adventures with your little one!

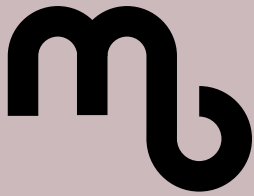

Register your product

www.mybabiie.com/warranties

In the first instance of needing assistance please contact your original place of purchase.

This product qualifies for 12 month warranty when registered through our website

mybabiie.com



My Babiie



@MyBabiieOfficial



My Babiie



@mybabiie_official



@MyBabiie

My Babiie Ltd, Paddock Wood, Kent, TN12 6EN

My Babiie EU , Generaal Vetterstraat 76A, 1059 BW Amsterdam, The Netherlands